

# SN883-100CH/34(CE)

EXPLODED  
VIEW AND SPARE  
PARTS LIST

EINZELTEILDAR-  
STELLUNG UND  
ERSATZTEILLISTE

SCHEMA ECLATE ET  
LISTE DES PIÉCES  
DE RECHANGE

ESPLOSO DEI  
COMPONENTI DE  
ELENCO DELLE  
PARTI DI RICAMBIO

DESPIECE DE LA  
MAQUINA Y LISTA  
DE RECAMBIOS

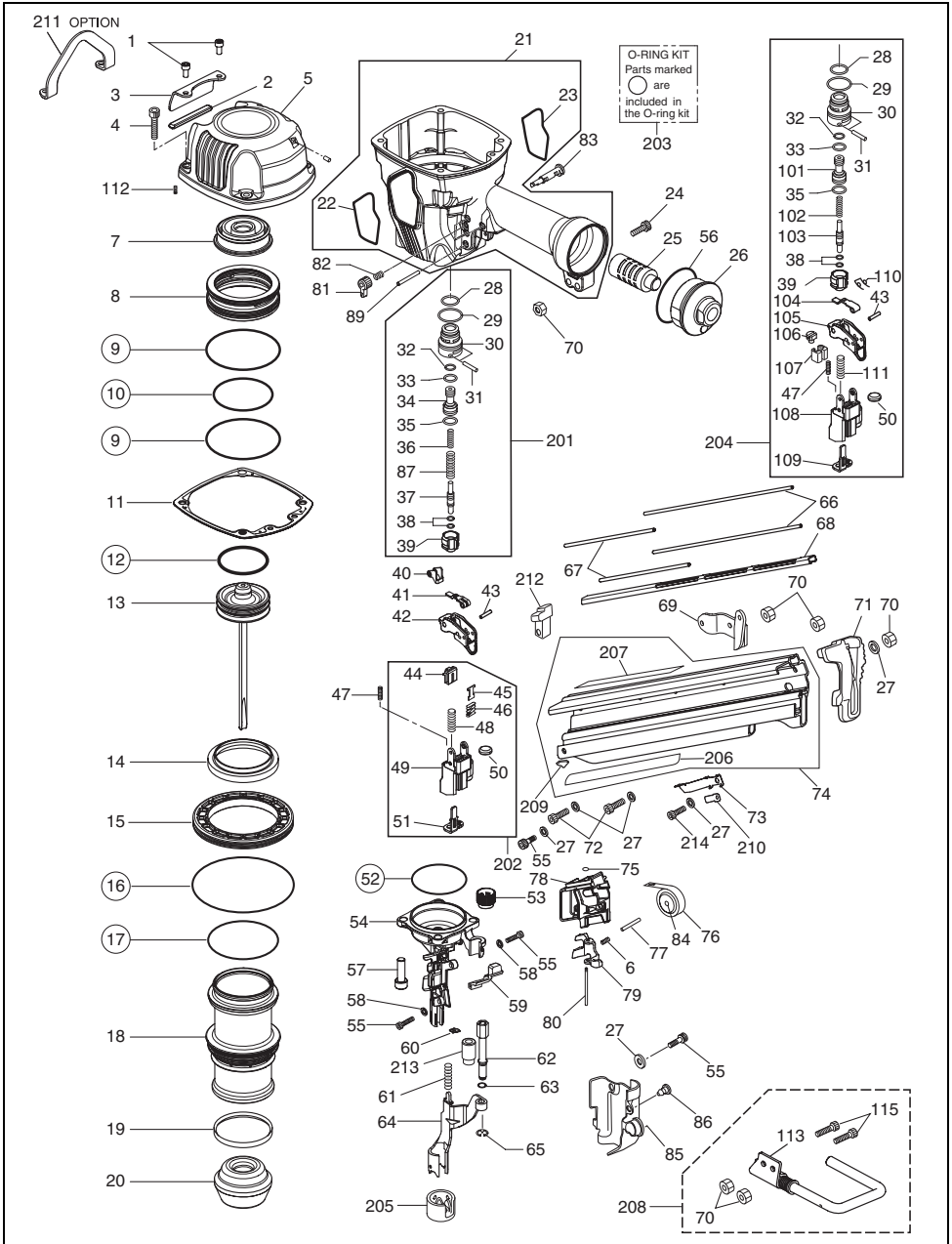

**SN883-100CH/34(CE)**

ITEM NO.	PART NO.	MATERIAL	ENGLISH	DEUTSCH	Français	ITALIANO	ESPAÑOL
1	BB40406	Steel	SCREW 5X12	SCHRAUBE 5X12	VIS 5X12	VITE 5X12	TORNILLO 5X12
2	KN12187	Stainless steel	EXHAUST FILTER	AUSLASSFILTER	FILTRE ECHAPPEMENT	FILTRO DI SCARICA	FILTRO DE ESCAPE
3	KN12194	Steel	EXHAUST COVER	ABSAUGHAUBE	CAPOT D'ASPIRATION	COPERCHIO DELLO SCARIO	CAMPANA DE ASPIRACION
4	BB40429	Steel	SCREW 6X28	SCHRAUBE 6X28	VIS 6X28	VITE 6X28	TORNILLO 6X28
5	KN70148	Aluminum	CYLINDER CAP UNIT	ZYLINDERDECKEL KOMPL.	COUVERCLE DE CYLINDRE COMPLET	GRUPPO COPERCHIO CILINDRO	CUBIERTA DE CILINDRO COMPL.
6	KK23976	Stainless steel	COMPRESSION SPRING 3976	DRUCKFEDER 3976	RESSORT A PRESSION 3976	MOLLA DI COMPRESIONE 3976	MUELLE DE COMPRESION 3976
7	KN12186	Urethane	PISTON STOP	KOLBENSCHLAG	BUTÉE DE PISTON	FERMO STANTUFFO	TOPE EMBOLO
8	KN1285	Aluminum	HEAD VALVE PISTON	KOPFVENTILKOLBEN	PISTON DE CLAPET DE TÊTE	STANTUFFO VALVOLA DI MANDATA	EMBOLO VALVULA DEL CABEZAL
9	HH14150	Rubber	O-RING AS568-150	O-RING AS568-150	JOINT TORIQUE AS568-150	O-RING AS568-150	ANILLO TÓRICO AS568-150
10	HH11161	Rubber	O-RING AS568-142	O-RING AS568-142	JOINT TORIQUE AS568-142	O-RING AS568-142	ANILLO TÓRICO AS568-142
11	KN70097	Stainless steel, Rubber	CYLINDER CAP SEAL UNIT	ZYLINDERABDECKSCHEIBE-KOMPL.	UNITE DE RONDELLE DE COUVERCLE DE CYLINDRE	GRUPPO COPERCHIO DI RONDELLA DI CILINDRO	COMPL. DE CUBIERTA DE ARANDELA DE CILINDRO
12	HH19218	Rubber	O-RING 4.5X48.8	O-RING 4.5X48.8	JOINT TORIQUE 4.5X48.8	O-RING 4.5X48.8	ANILLO TÓRICO 4.5X48.8
13	KN70149	Magnesium, Steel	MAIN PISTON UNIT	ARBEITSKOLBEN KOMPL.	PISTON DE TRAVAIL COMPLET	GRUPPO STANTUFFO OPERATORE	EMBOLO DE TRAJAO COMPL.
14	KN12189	Urethane	CYLINDER SEAL	ZYLINDERABDECKSCHEIBE	RONDELLE DE CYLINDRE	RONDELLA DI CILINDRO	ARANDELA DE CILINDRO
15	KN12190	Polyacetal	CYLINDER RING	ZYLINDERRING	JOINT DE CYLINDRE	ANELLO DI CILINDRO	ANILLO DE CILINDRO
16	HH12121	Rubber	O-RING 1AG100	O-RING 1AG100	JOINT TORIQUE 1AG100	O-RING 1AG100	ANILLO TÓRICO 1AG100
17	HH12107	Rubber	O-RING 1AG70	O-RING 1AG70	JOINT TORIQUE 1AG70	O-RING 1AG70	ANILLO TÓRICO 1AG70
18	KN12583	Aluminum	CYLINDER	ZILINDER	CYLINDRE	CILINDRO	CILINDRO
19	CN35325	Rubber	CHECK PAWL	SPERRKLINKE	CLIQUET D'ARRET	NOTTOLINO DI ARRESTO	TRINQUETE
20	KN12193	Rubber	BUMPER	STOSSDÄMPFER	AMORTISSEUR	AMMORTIZZATORE	AMORTIGUADOR
21	KN81055	Aluminum	FRAME	GEHAUSE	BOÎTIER	ALLOGGIAMENTO	CARCASE
22	KN12205	Aluminum	NAME LABEL A	NAMENSSCHILD A	JOINT DE NOM A	SIGILLO DI NOME A	JUNTA DE NOMBRE A
23	KN12206	Aluminum	NAME LABEL B	NAMENSSCHILD B	JOINT DE NOM B	SIGILLO DI NOME B	JUNTA DE NOMBRE B
24	BB40460	Steel	SCREW 5X28	SCHRAUBE 5X28	VIS 5X28	VITE 5X28	TORNILLO 5X28
25	CN35685	Nylon	END CAP FILTER SA-10	ABSCHLUSSKAPPEFILTER SA-10	FILTRE SA-10 DE CAPOT DE RECOUVREMENT	FILTRO DE CAPERUZA DE CIERRE SA-10	FILTRO DEL CAPPUCCIO DI CHIUSURA SA-10
26	KN12436	Aluminum	END CAP	ABSCHLUSSKAPPE	CAPOT DE RECOUVREMENT	CAPPUCCIO DI CHIUSURA	CAPERUZA DE CIERRE
27	EE31121	Steel	PLANE WASHER 1-5	GLATTE UNTERLEGSCHIBE 1-5	RONDELLE LISSE 1-5	RONDELLA PIANA 1-5	ARANDELA LISA 1-5
28	HH11125	Rubber	O-RING 1AP12	O-RING 1AP12	JOINT TORIQUE 1AP12	O-RING 1AP12	ANILLO TÓRICO 1AP12
29	HH11138	Rubber	O-RING 1AP20	O-RING 1AP20	JOINT TORIQUE 1AP20	O-RING 1AP20	ANILLO TÓRICO 1AP20
30	CN33909	Polyacetal	TRIGGER VALVE HOUSING	BETÄTIGUNGSVENTILGEHÄUSE	CARTER DE SOUPE DE DECLANCHEMENT	ALLOGGIO DELLA VALVOLA DI INNESCO	CUBIERTA DE VALVULA DEL DISPARADOR
31	FF30161	Stainless steel	PARALLEL PIN 161	PARALLELBOLZEN 161	GOUPILLE PARALLELE 161	PERNO PARALLELO 161	PERNO PARALELO 161
32	HH11119	Rubber	O-RING 1AP6	O-RING 1AP6	JOINT TORIQUE 1AP6	O-RING 1AP6	ANILLO TÓRICO 1AP6
33	HH11209	Rubber	O-RING 1BP7	O-RING 1BP7	JOINT TORIQUE 1BP7	O-RING 1BP7	ANILLO TÓRICO 1BP7
34	CN31589	Polyacetal	PILOT VALVE	STEUERVENTIL	VANNE-PILOTE	VALVOLA DI COMANDO	VÁLVULA DE CONTROL
35	HH11113	Rubber	O-RING 1AP9	O-RING 1AP9	JOINT TORIQUE 1AP9	O-RING 1AP9	ANILLO TÓRICO 1AP9
36	KK24161	Stainless steel	COMPRESSION SPRING 4161	DRUCKFEDER 4161	RESSORT A PRESSION 4161	MOLLA DI COMPRESIONE 4161	MUELLE DE COMPRESION 4161
37	KN12214	Steel	TRIGGER VALVE STEM	BETÄTIGUNGSVENTILSCHAFT	TIGE DE SOUPE DE COMMANDE	STELO VALVOLA DI AZIONAMENTO	VASTAGO VALVULA DE ACCIONAMIENTO
38	HH11901	Rubber	O-RING 1B 1.4X2.5	O-RING 1B 1.4X2.5	JOINT TORIQUE 1B 1.4X2.5	O-RING 1B 1.4X2.5	ANILLO TÓRICO 1B 1.4X2.5
39	CN33910	Polyacetal	TRIGGER VALVE CAP	BETÄTIGUNGSVENTILDECKEL	CAPUCHON DE SOUPE DE COMMANDE	COPERCHIO VALVOLA DI AZIONAMENTO	CAPERUZA VALVULA DE ACCIONAMIENTO
40	HS10144	Steel	CONTACT LEVER B	KONTAKTHEBEL B	LEVIER DE CONTACT B	LEVA DI CONTATTO B	PALANCA DE CONTACTO B
41	KN12274	Steel	CONTACT LEVER A	KONTAKTHEBEL A	LEVIER DE CONTACT A	LEVA DI CONTATTO A	PALANCA DE CONTACTO A
42	KN12401	Polyacetal	TRIGGER	BETÄTIGUNGHEBEL	LEVIER DE COMMANDE	GRILLETTE	PALANCA DE ACCIONAMIENTO
43	FF22401	Stainless steel	ROLL PIN 3X16	ROLLENBOLZEN 3X16	TOURILLON DE CYLINDRE 3X16	PERNO DI ROTOLAMENT 3X16	PERNO DE RODILLO 3X16
44	HS10145	Nylon	SWITCH LEVER A	FAHRSCHALTHEBEL A	LEVIER D'INTERRUPTEUR A	LEVA DELL'INTERRUTTORE A	PALANCA DEL INTERRUPTOR A
45	HS10146	Steel	SWITCH LEVER B	FAHRSCHALTHEBEL B	LEVIER D'INTERRUPTEUR B	LEVA DELL'INTERRUTTORE B	PALANCA DEL INTERRUPTOR B
46	CN34500	Stainless steel	SWITCH SPRING	SCHALTERFEDER	RESSORT D'INTERRUPTEUR	MOLLA DELL'INTERRUTTORE	MUELLE DEL INTERRUPTOR
47	KK23129	Stainless steel	COMPRESSION SPRING 3129	DRUCKFEDER 3129	RESSORT A PRESSION 3129	MOLLA DI COMPRESIONE 3129	MUELLE DE COMPRESION 3129
48	KK29025	Stainless steel	COMPRESSION SPRING 9025	DRUCKFEDER 9025	RESSORT A PRESSION 9025	MOLLA DI COMPRESIONE 9025	MUELLE DE COMPRESION 9025
49	KN12207	Nylon	ARM GUIDE	ARMFÜHRER	GUIDE DE BRAS DE CONTACT	GUIDA DEL BRACCIO DI CONTATTO	GUÍA DEL BRAZO
50	TA15144	Rubber	EXHAUST SEAL	AUSLASSSCHIBE	RONDELLE ECHAPPEMENT	RONDELLA DI SCARICA	ARANDELA DE ESCAPE
51	KN12212	Steel	CONTACT ARM A	KONTAKTARM A	BARRE DE CONTACT A	BRACCIO DI CONTATTO A	BRAZO DE CONTACTO A
52	HH14729	Rubber	O-RING AS568-144	O-RING AS568-144	JOINT TORIQUE AS568-144	O-RING AS568-144	ANILLO TÓRICO AS568-144
53	KN12200	Polyacetal	ADJUST DIAL	EINSTELLVORWAHLKNOPF	CADRAN DE REGLAGE	MANOPOLA DI REGOLAZIONE	CUADRANTE DE AJUSTE
54	KN12584	Steel	NOSE	NAGLERNASE	NEZ DE CLOUEUR	PUNTA SPARACHIODI	NARIZ
55	BB40415	Steel	SCREW 5X10	SCHRAUBE 5X10	VIS 5X10	VITE 5X10	TORNILLO 5X10
56	HH12111	Rubber	O-RING 1AG45	O-RING 1AG45	JOINT TORIQUE 1AG45	O-RING 1AG45	ANILLO TÓRICO 1AG45
57	BB40443	Steel	SCREW 8X28	SCHRAUBE 8X28	VIS 8X28	VITE 8X28	TORNILLO 8X28
58	EE39172	Steel	PLANE WASHER 5.1X12X1.2	GLATTE UNTERLEGSCHIBE 5.1X12X1.2	RONDELLE LISSE 5.1X12X1.2	RONDELLA PIANA 5.1X12X1.2	ARANDELA LISA 5.1X12X1.2
59	KN12540	Rubber	MAGAZINE GUIDE B	MAGAZINFÜHRER B	GUIDE DE MAGASIN B	GUIDA CARICATORE B	GUÍA DE CARGADOR B

## SN883-100CH/34(CE)

ITEM NO.	PART NO.	MATERIAL	ENGLISH	DEUTSCH	FRAANÇAIS	ITALIANO	ESPAÑOL
60	KN12216	Rubber	MAGAZINE GUIDE A	MAGAZINFÜHRER A	GUIDE DE MAGASIN A	GUIDA CARICATORE A	GUIA DE CARGADOR A
61	KK29024	Stainless steel	COMPRESSION SPRING	DRUCKFEDER	RESSORT Á PRESSION	MOLLA DI COMPRESSIONE	MUELLE DE COMPRESION
62	KN12590	Steel	CONTACT BOLT	KONTAKTSCHRAUBBOLZEN	BOULON DE CONTACT	BULLONE DI CONTATTO	PERNO DE CONTACTO
63	HH19722	Rubber	O-RING 1A 1.5x5	O-RING 1A 1.5x5	JOINT TORIQUE 1A 1.5x5	O-RING 1A 1.5x5	ANILLO TORICO 1A 1.5x5
64	KN70120	Steel	CONTACT ARM B UNIT	KONTAKTARM B	BARRE DE CONTACT B	BRACCIO DI CONTATTO B	BRAZO DE CONTACTO B
65	JJ10102	Stainless steel	E-RETAINING RING 5	E-HALTERING 5	BAGUE DE RETENUE E 5	ANELLO DI RITEGNO E 5	ANILLO DE RETENCIÓN EN E 5
66	KN12210	Polyacetal	NAIL GUIDE B	NAGELFÜHRER B	GUIDE DE CLOUS B	GUIDA DI CHIODI B	GUIA DE CLAVOS B
67	KN12227	Stainless steel	NAIL GUIDE A	NAGELFÜHRER A	GUIDE DE CLOUS A	GUIDA DI CHIODI A	GUIA DE CLAVOS A
68	KN12226	Stainless steel	NAIL COVER	NAGELDECKEL	COUVERCLE DE CLOUS	COPERCHIO DI CHIODI	CUBIERTA DE CLAVOS
69	KN12574	Steel	TAIL HANGER	SCHWANZHALTER	SUPPORT DE QUEUE	SUPPORTO DI CODA	SOPORTE DE COLA
70	CC49411	Steel, Nylon	NUT M5	MUTTER M5	ECROU M5	DADO M5	TUERCA M5
71	KN12589	Nylon	TAIL COVER	SCHWANZDECKEL	COUVERCLE DE QUEUE	COPERCHIO DI CODA	CUBIERTA DE COLA
72	BB40408	Steel	SCREW 5X14	SCHRAUBE 5X14	VIS 5X14	VITE 5X14	TORNILLO 5X14
73	KN12419	Stainless steel	NAIL STOPPER	NAGELSTOPPER	PIECE ARRET DE CLOUS	FERMO DI CHIODI	TOPE DE CLAVOS
74	KN12585	Aluminum	MAGAZINE	MAGAZIN	MAGASIN	CARICATORE	CARGADOR
75	EE39609	Steel	RUBBER WASHER 1.8x6x2	GUMMISCHLEIBE 1.8x6x2	DISQUE DE CAOUTCHOUC 1.8x6x2	ROUNDELLA IN GOMMA 1.8x6x2	ARANDELA DE CAUCHO 1.8x6x2
76	KK44021	Stainless steel	SPIRAL SPRING 4021	SPIRALFEDER 4021	RESSORT SPIRAL 4021	MOLLA SPIRALE 4021	MUELLE ESPIRAL 4021
77	FF31572	Stainless steel	PARALLEL PIN 1572	PARALLELBOLZEN 1572	GOUPILLE PARALLELE 1572	PERNO PARALLELO 1572	PERNO PARALELO 1572
78	KN12232	Nylon	PUSHER HOLDER	SCHIEBERHALTER	SUPPORT DE POUSSOIR	SUPPORTO SPINGITOIO	SOPORTE DE EMPUJADOR
79	KN12230	Steel	PUSHER	SCHIEBER	POUSSOIR	SPINGITOIO	EMPUJADOR
80	FF31603	Steel	PARALLEL PIN 1603	PARALLELBOLZEN 1603	GOUPILLE PARALLELE 1603	PERNO PARALLELO 1603	PERNO PARALELO 1603
81	CN35075	Nylon	TRIGGER LOCK LEVER	BETÄTIGUNGSPERREHEBEL	LEVIER DE BLOCAGE DE LA COMMANDE	LEVA DI SICURA GRILLETTO	PALANCA BLOQUEO DE ACCIONAMIENTO
82	KK23507	Stainless steel	COMPRESSION SPRING 3507	DRUCKFEDER 3507	RESSORT Á PRESSION 3507	MOLLA DI COMPRESSIONE 3507	MUELLE DE COMPRESION 3507
83	CN35074	Nylon	TRIGGER LOCK DIAL	BETÄTIGUNGSPERREKNOPF	DISQUE DE BLOCAGE DE LA COMMANDE	DISCO DI SICURA GRILLETTO	DISCO BLOQUEO DE ACCIONAMIENTO
84	GN10424	Polyacetal	SPRING COLLAR	FEDERSSTELLRING	COLLIER DE RESSORT	COLLARE DELLA MOLLA	COLLAR DE MUELLE
85	KN12573	Nylon	ARM COVER	ARMABECKUNG	COUVERCLE DE BRAS	COPERCHIO DEL BRACCIO	CUBIERTA DEL BRAZO
86	CN31083	Rubber	DUST COVER HOOK	STAUBDECKELHAKEN	CROCHET DE COUVERCLE ANTI-POUSSIERE	GANCIO COPERCHIO PARAPOLVERE	GANCIO DE LA TAPA GUARDAPOLVO
87	KK24162	Stainless steel	COMPRESSION SPRING 4162	DRUCKFEDER 4162	RESSORT Á PRESSION 4162	MOLLA DI COMPRESSIONE 4162	MUELLE DE COMPRESION 4162
89	FF21235	Steel	ROLL PIN 3X30	ROLLENBOLZEN 3X30	TOURILLON DE CYLINDRE 3X30	PERNO DI ROTOLAMENTO 3X30	PERNO DE RODILLO 3X30
91	KN12420	Stainless steel	NAIL STOPPER B	NAGELSTOPPER B	PIECE ARRET DE CLOUS B	FERMO DI CHIODI B	TOPE DE CLAVOS B
101	CN32246	Polyacetal	PILOT VALVE	STEUERVENTIL	VANNE-PILOTE	VALVOLA DI COMANDO	VÁLVULA DE CONTROL
102	KK24123	Stainless steel	COMPRESSION SPRING 4123	DRUCKFEDER 4123	RESSORT Á PRESSION 4123	MOLLA DI COMPRESSIONE 4123	MUELLE DE COMPRESION 4123
103	CN35128	Steel	TRIGGER VALVE STEM	BETÄTIGUNGSVENTILSCHAF	TIGE DE SOUPEE DE COMMANDE	STELO VALVOLA DI AZIONAMENTO	VASTAGO VALVULA DE ACCIONAMIENTO
104	HN10100	Steel	CONTACT LEVER	KONTAKTHEBEL	LEVIER DE CONTACT	LEVA DI CONTATTO	PALANCA DE CONTACTO
105	HS10118	Polyacetal	TRIGGER	BETÄTIGUNGSHABEL	LEVIER DE COMMANDE	GRILLETTO	PALANCA DE ACCIONAMIENTO
106	HN10786	Stainless steel	ARM GUIDE PLATE	ARMFUHRERSPLATTE	PLAQUE DE GUIDE DE BRAS	PLACCA DI GUIDA BRACCIO	PLACA DE GUIA DEL BRAZO
107	KN12277	Steel	CONTACT ARM A GUIDE	KONTAKTARMFUHRER A	GUIDE DE BRAS DE CONTACT A	GUIDA DEL BRACCIO DI CONTATTO A	GUIA DEL BRAZO DE CONTACTO A
108	KN12278	Nylon	ARM GUIDE	ARMFUHRER	GUIDE DE BRAS DE CONTACT	GUIDA DEL BRACCIO DI CONTATTO	GUIA DEL BRAZO
109	KN12276	Steel	CONTACT ARM A	KONTAKTARM A	BARRE DE CONTACT A	BRACCIO DI CONTATTO A	BRAZO DE CONTACTO A
110	KK33300	Stainless steel	TORSION SPRING 3300	TORSIONSFEDER 3300	RESSORT DE TORSION 3300	MOLLA DI TORSIONE 3300	MUELLE DE TORSION 3300
111	KK23973	Stainless steel	COMPRESSION SPRING 3973	DRUCKFEDER 3973	RESSORT Á PRESSION 3973	MOLLA DI COMPRESSIONE 3973	MUELLE DE COMPRESION 3973
112	KK23944	Stainless steel	COMPRESSION SPRING 3944	DRUCKFEDER 3944	RESSORT Á PRESSION 3944	MOLLA DI COMPRESSIONE 3944	MUELLE DE COMPRESION 3944
113	KN12405	Steel, Stainless steel	RAFTER HOOK	DACHHAKEN	CROCHET DE COMBLE	GANCIO DI TETTO	GANCIO DE CIMA
115	BB40027	Steel	SCREW 5X30	SCHRAUBE 5X30	VIS 5X30	VITE 5X30	TORNILLO 5X30
201	KN81017		TRIGGER VALVE KIT	BETÄTIGUNGSVENTILKIT	KIT DE SOUPEE DE COMMANDE	KIT VALVOLA DI AZIONAMENTO	KIT VÁLVULA DE ACCIONAMIENTO
202	KN81060		ARM GUIDE KIT	KIT ARMFUHRERSKIT	KIT DE GUIDE DE BRAS	KIT DELLA GUIDA BRACCIO	KIT DE LA GUIA DEL BRAZO
203	KN81016		O-RING KIT	O-RINGSKIT	KIT DE JOINT TORIQUE	KIT DI O-RING	KIT DE ANILLO TORICO
204	KN81027		SEQUENTIAL TRIP KIT	SEQUENTIELLELAUSLÖSUNGKIT	KIT DE DECLENCHEMENT SEQUENTIEL	KIT DI AZIONAMENTO EQUENZIALE	KIT DE DISPARO SECUENCIAL
205	KN11237	Urethane	CONTACT TIP	KONTAKTKAPPE	CAPUCHON DE CONTACT	COPERCHIO DI CONTATTO	CAPERUZA DE CONTACTO
206	KN12591	Polyethylene terephthalate	NAME LABEL	NAMENSSCHILD	JOINT DE NOM	SIGILLO DI NOME	JUNTA DE NOMBRE
207	KN12592	Polyethylene terephthalate	CAUTION LABEL	VORSICHTSSCHILD	ETIQUETTE DE PRECAUTION	ETICHETTA DI PRECAUZIONE	ETIQUETA DE PRECAUCION
208	KN81035		RAFTER HOOK KIT	KIT DES DACHHAKENS	KIT DE CROCHET DE COMBLE	KIT DI GANCIO DI TETTO	EQUIPO DE GANCIO DE CIMA
209	KN12549	Polyethylene terephthalate	WARNING LABEL	WARNSCHILD	PLAQUE D'AVERTISSEMENT	TARGHETTA AVVERTENZE	ROTULO AVISADOR DE PELIGRO
210	KN12420	Stainless steel	NAIL STOPPER B	NAGELSTOPPER B	PIECE ARRET DE CLOUS B	FERMO DI CHIODI B	TOPE DE CLAVOS B
211	KN81054		BODY HANGER KIT	GEHAUSEAUFHANGERSKIT	KIT DE SUPPORT DE BOITIER	KIT DI SUPPORTO DIALLOGGIAMENTO	KIT DE SUSPENSION DE CARCASA
212	KN12600		CONTACT GUIDE	KONTAKTFÜHRER	GUIDE DE CONTACT	GUIA DE CONTACTO	GUIDA DI CONTATTO
213	KN12599		CONTACT SPRING COLLAR	KONTAKTFEDERSSTELLRING	COLLIER DE RESSORT DE CONTACT	COLLAR DE MUELLE DE CONTACTO	COLLARE DELLA MOLLA DI CONTATTO
214	BB40404	Steel	SCREW 5X16	SCHRAUBE 5X16	VIS 5X16	VITE 5X16	TORNILLO 5X16